



Kit Contents			
	Description	Part No	Pcs
1	Shock absorber front	BMV 5U11	2
2	Length adjuster	06245-03	2
3	Nylon stop screw	05410-01	2
4	Helper spring		2
5	Spring support	05193-14	2
6	Main spring		2
7	Upper spring seat	06211-01	2
8	Lower top mount spacer	05688-07	2
9	Top mount L/R	05927-*	2
10	Upper top mount spacer	05688-06	2
11	Lock nut	00539-01	2
12	Preload adjuster tool	03199-01	1
13	ARB drop link	05928-11	2
14	Öhlins sticker kit	10207-01	1
15	Öhlins Owners manual	07445-01	1

Note!

Please note that there can be small differences between your product and the images in these instructions.

Note!

Please note that during storage and transport, especially at high ambient temperature, some of the oil and grease used for assembly may leak and stain the packaging. This will not cause damage to the product, wipe off the excessive oil or grease with a cloth.

Note!

If the vehicle is equipped with OEM electronic shock absorbers, use Öhlins cancellation kit to avoid error codes. For more information and part number, please visit www.ohlins.com or contact an Öhlins dealer.

Note!

Please note that this kit is designed for maximum track performance using motorsport components and because of that, there is an increased risk of noise that may be heard inside the vehicle during usage on open roads.

Note!

Before you install this product, check the kit contents. If anything is missing, please contact an Öhlins dealer.

Warning!

Before you install this product, read the Öhlins Owner's manual. This product is an important part of the vehicle and the vehicle stability.

Note!

When using aftermarket wheels with different widths and offsets, the use of spacers to clear the suspension may be necessary.

Note!

If the vehicle is equipped with OEM electronic shock absorbers, use Öhlins cancellation kit to avoid error codes. For more information and part number, please visit www.ohlins.com or contact an Öhlins dealer.

*BMW M2 Comp./M3/M4: 05927-24/25
BMW M2 non-comp: 05927-26/27

Shock absorber kit Advanced Trackday for BMW M2/M3/M4 F87/F80/F82 2014-2019

BMV MU21 front

Mounting Instructions



MOUNTING INSTRUCTIONS

⚠ Warning!

We strongly recommend to let an Öhlins dealer install this product.

⚠ Warning!

If you work with a lifted vehicle, make sure that it is safely supported to prevent it from tipping over.

👁 Note!

When you work with this product, see the vehicle service manual for vehicle specific procedures and important data.

👁 Note!

Before you install this product clean the vehicle.

1

Raise the vehicle and put it on jack stands.

2

Remove the wheels.

3

Loosen the bolt for the lower shock attachments.

👁 Note!

Support the wheel hubs in an appropriate way on each side of the vehicle so that the brake hoses can not be damaged.

4

Loosen the upper attachments. Remove the original shock absorbers from the car.

5

Assemble the front shock absorbers according to figure 1: Install the length adjuster (2) to the shock absorber and adjust the position according to fig 10. Install the nylon stop screw (3) in the groove in the length adjuster, hand tighten for now. Install the helper spring (4), the spring support (5), the main spring (6), the upper spring seat (7), the lower top mount spacer (8), the Öhlins top mount (9), the upper top mount spacer (10) and the lock nut (11). Tighten the lock nut to 40 Nm.

👁 Note!

When tightening the top mount nut, the shock absorber shaft end must be held in position with an allen key.

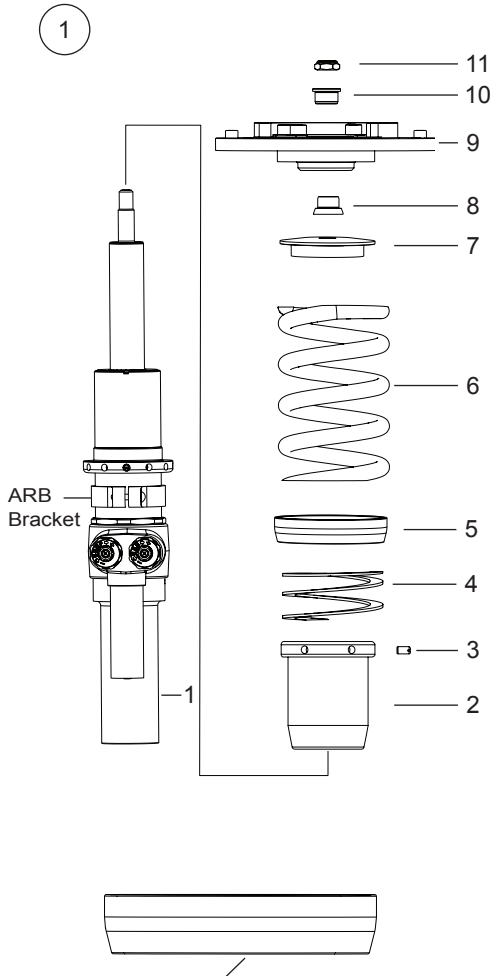

👁 Note!

Please note orientation of the spring support. The smaller diameter should be installed towards the helper spring.

MOUNTING INSTRUCTIONS

6

Fit the shock absorber to the vehicle upright. Position it according to Fig 2 so that the adjusters on the shock absorber is pointing towards the front of the vehicle/direction of travel. Also align the slit in the length adjuster with the slit in the vehicle upright. Tighten the nylon lock screw in the length adjuster. Make sure there is clearance between the upright and reservoir according to fig 3.

7

Tighten the lower attachment.

8

Fasten the upper attachment/top mount to the vehicle.

Note!

Please note that depending on vehicle model and year model, different numbers and different lengths of the screws for attaching the top mount should be used. Please see page 5 for more information.

9

Fit the OE aluminum strut brace to the top mounts with the supplied M8x20 screws and tighten to 24 Nm. Please see Fig 9.

ARB drop links

10

Loosen the nuts holding the uniballs and adjust the length of the drop links according to Fig 4. Adjust both ends evenly. Please note that one end of the drop link is reversed threaded.

11

Loosen the screw on the ARB bracket on the shock absorber and adjust and position it according to fig 5.

Warning!

The adjustment range of the drop link is 286-310 mm. Never adjust it beyond 310 mm.

Note!

Please note that the ARB bracket is rotated and positioned differently depending on what car model the shock absorber is fitted to.

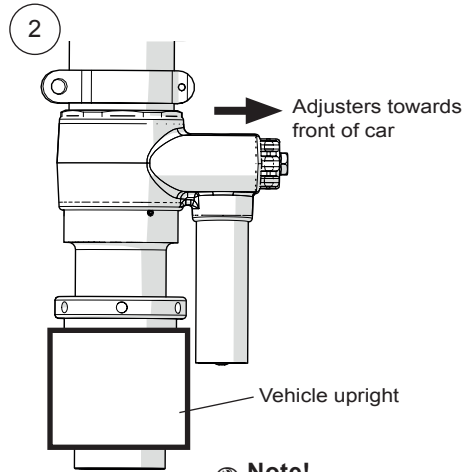

Note!

In some cases there may be a small gap between the upright and the length adjuster. This is considered OK and not an error.

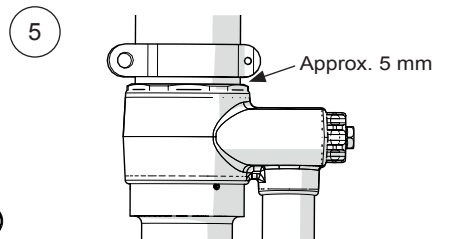
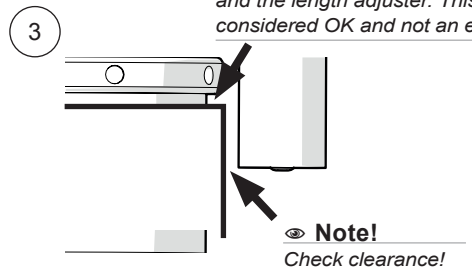

➔ Towards front of the car

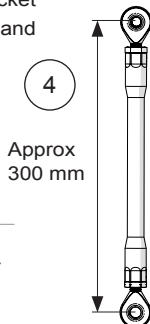

MOUNTING INSTRUCTIONS

12

Fit the drop link to the shock absorber ARB bracket according to Fig 6 with a conical spacer on each side of the uniball. Please note that the drop link screws are in different lengths. The shorter 45 mm screw should be connected to the shock absorber ARB bracket. Tighten the screw to 40 Nm.

13

Connect the drop link to the anti roll bar of the vehicle according to fig 7. Fit the lock nut and washer and tighten to 40 Nm

👁 Note!

The recommended installation lengths and angles of the ARB drop links are to be considered approximations. Due to the many ways of adjusting lengths of both the ARB drop links, the ARB bracket on the shock absorber and variations on different vehicles, it's hard to specify any exact lengths and angles for the installation.

14

Make sure that all removed parts are reinstalled in the same way as they were before the installation of the Öhlins shock absorber.

15

Reinstall the wheel.

👁 Note!

Make sure that all bolts are tightened to the correct torque and that nothing fouls or restricts movement of the strut when it is being fully compressed or extended. Test this over the whole steering range from lock to lock. Pay extra attention to the installed ARB drop link that it clears all parts of the vehicle during lock to lock steering range. If any interference occurs, readjust lengths and angles for the drop link until no interference occurs.

Some of the original bolts need to be replaced when removed. See the service manual for your vehicle or contact an Öhlins dealer.

👁 Note!

Make sure there is enough clearance between the wheel and the suspension according to Fig 8. When using wider wheel options the use of spacers may be necessary.

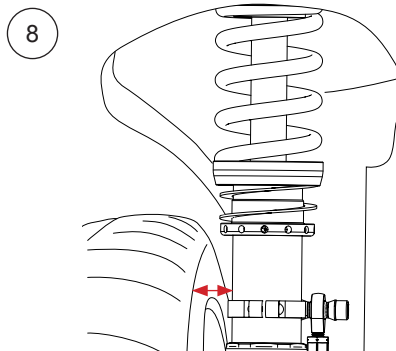
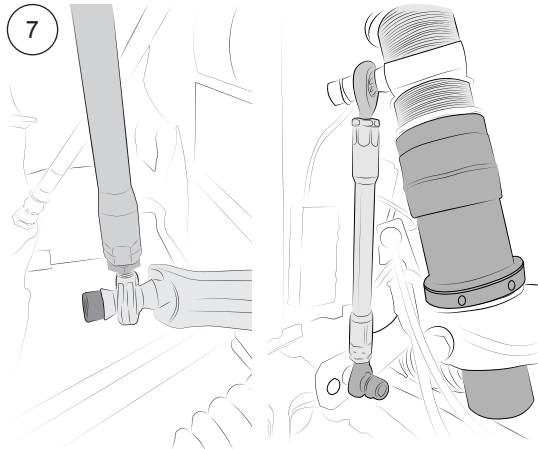
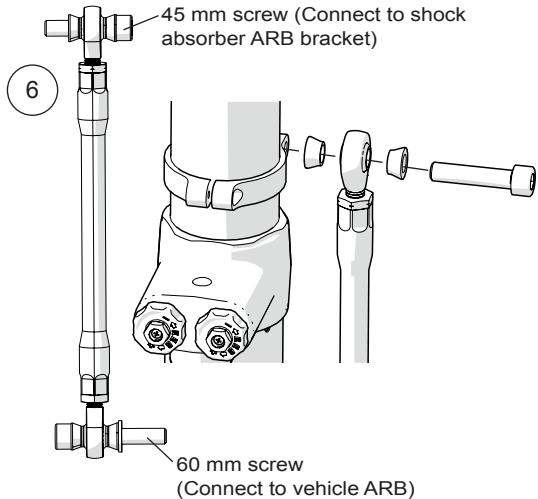

ADJUSTMENTS - TOP MOUNT

👁 Note!

Depending on year model, the F8x came with different screws for attaching the top mount to the vehicle. Please see screw (1) in Fig 9 below. Early models came with 3x M10 screws and newer with 5x M8. The Öhlins top mounts will fit all these models. Use the supplied M8 screws (1) to fit the Öhlins top mount to the vehicle.

1

The Öhlins top mounts will adjust both camber and caster. To adjust, loosen the 3x M8 screws (2) according to Fig 9 slightly and push/pull the top mount inward/outward. Adjust until desired amount of caster/camber is achieved and tighten the screws to 24Nm.

👁 Note!

Picture shows left hand side top mount.

9

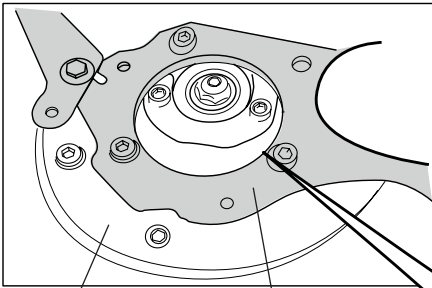

👁 Note!

Please note that the F8x model can be equipped with or without an upper reinforcement plate. For vehicles **with** reinforcement plate, please use supplied M8x20 screws for position (1) For vehicles **without** reinforcement plate, please use supplied M8x16 screws for position (1).

👁 Note!

Please note that the screws (2) may be inaccessible when maximum camber/caster is adjusted. In order to be able to tighten/untighten the screws, the OE aluminum strut brace have to be removed from the vehicle.

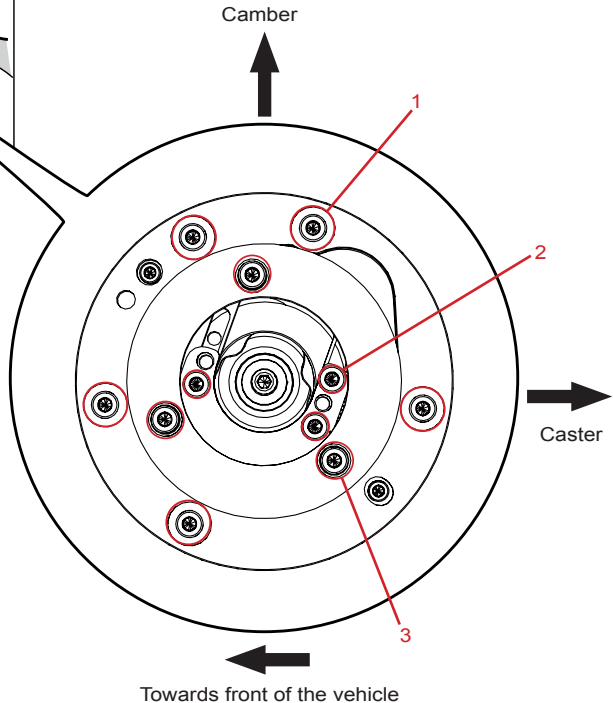

👁 Note!

Screws M8x20 (3) used to fit OE aluminum strut brace.

ADJUSTMENTS

⚠ Warning!

Before you ride/drive, always make sure that the setup is according to the recommended setup data. Read about adjustments and setting up in the Öhlins Owner's Manual before you make any adjustments. Contact an Öhlins dealer if you have any questions about setting up.

SETUP DATA

	Street	Track
Compression damping	15 clicks	10 clicks
Rebound damping	15 clicks	10 clicks

Recommended Springs

Main Spring

Length	Rate	Öhlins#
140 mm	140 N/mm	48140-25

Helper spring

Length	Rate	Öhlins#
73 mm	7.5 N/mm	05173-12

Recommended length adjuster position

For BMW M2 models: X=35 mm

For BMW M3/M4 models: X=28 mm

⚠ Warning!

Never adjust the length adjuster to a position greater than 40 mm. Please also note that moving the length adjuster outside the recommended position may cause the wheel to hit the inner wheel well/fender liner.

Recommended installed spring package length

192 mm

Measure from upper edge of main spring to lower part of helper spring. Adjust the installed spring package length by turning the spring preload adjuster until desired ride height is achieved.

Öhlins products are subject to continuous improvement and development, therefore, although these instructions include the most up-to-date information available at the time of printing, minor updates may occur.

To find the latest information contact an Öhlins distributor. Please contact Öhlins if you have any questions regarding the contents in this document.

Part no. MI_BMV MU21_0
Issued 2023-10-09

© Öhlins Racing AB. All rights reserved. Any reprinting or unauthorized use without the written permission of Öhlins Racing AB is prohibited.

Öhlins Racing AB
Box 722
S-194 27 Upplands Väsby, Sweden
Phone +46 8 590 025 00
fax +46 8 590 025 80



www.ohlins.com

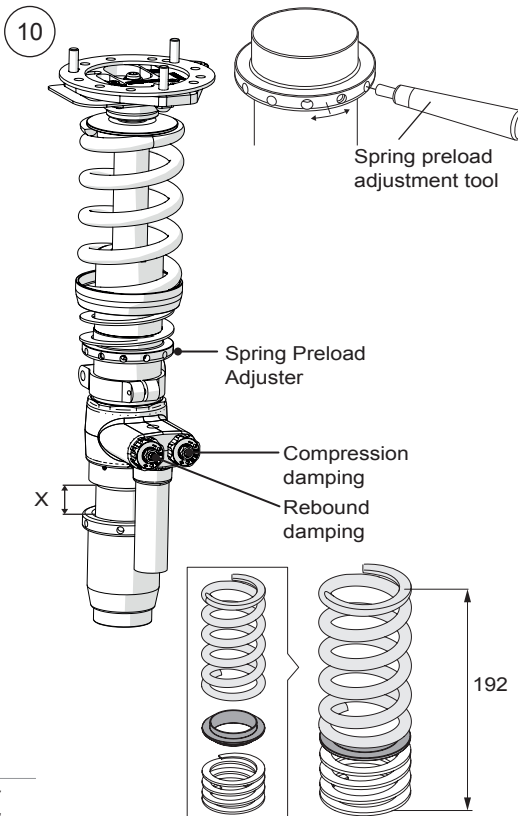

Depending on car model and equipment, the ride height at the recommended installed spring package length may vary.

⚠ Warning!

Never adjust the spring preload adjuster so that the installed spring package length is shorter than 192 mm. If that is done the spring may coil bind.



Kit Contents			
	Description	Part No	Pcs
1	Shock absorber	BMV 6U20	2
2	Screw M10x70mm	00439-22	2
3	Washer	00426-08	2
4	M10 lock nut	00539-04	2
5	Rear top mount	05926-12	2
6	Spring adjuster	24651-09	2
7	Spring platform	06289-05	2
8	Nylon screw	05410-01	2
9	Main spring		2
10	Spring support	05193-07	2
11	Helper spring		2
12	Lower spring seat	25618-32	2
13	Screw M8x30	05404-09	6

Note!

Please note that there can be small differences between your product and the images in these instructions.

Note!

Please note that during storage and transport, especially at high ambient temperature, some of the oil and grease used for assembly may leak and stain the packaging. This will not cause damage to the product, wipe off the excessive oil or grease with a cloth.

Note!

If the vehicle is equipped with OEM electronic shock absorbers, use Öhlins cancellation kit to avoid error codes. For more information and part number, please visit www.ohlins.com or contact an Öhlins dealer.

Note!

Please note that this kit is for track use purpose only! There is an increased risk of noise that could be heard inside the vehicle during usage on open roads.

Note!

Before you install this product, check the kit contents. If anything is missing, please contact an Öhlins dealer.

Warning!

Before you install this product, read the Öhlins Owner's manual. This product is an important part of the vehicle and the vehicle stability.

Shock absorber kit Advanced Trackday for BMW M2/M3/M4 F87/F80/F82 2014-2019

BMV MU21 rear

Mounting Instructions



MOUNTING INSTRUCTIONS

⚠ Warning!

We strongly recommend to let an Öhlins dealer install this product.

⚠ Warning!

If you work with a lifted vehicle, make sure that it is safely supported to prevent it from tipping over.

👁 Note!

When you work with this product, see the vehicle service manual for vehicle specific procedures and important data.

👁 Note!

Before you install this product clean the vehicle.

1

Raise the vehicle and put it on jack stands.

2

Remove the wheels.

3

Loosen the bolt for the lower shock attachments.

👁 Note!

Support the wheel hubs in an appropriate way on each side of the vehicle so that the brake hoses can not be damaged.

4

Loosen the upper attachments. Remove the original shock absorbers from the car.

5

Remove the OE spring and spring seats.

6

Remove the OEM upper spring cup according to figure 2.

7

Install the spring seat (7) to the spring adjuster (6) and set the position according to fig 5. Install the nylon screw (8) and tighten to lock the spring seat in position.

8

Install the spring adjuster (6), the main spring (9), the spring support (10), the helper spring (11) and the lower spring seat (12) to the vehicle.

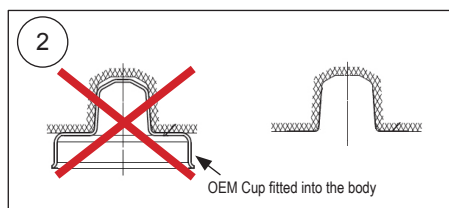
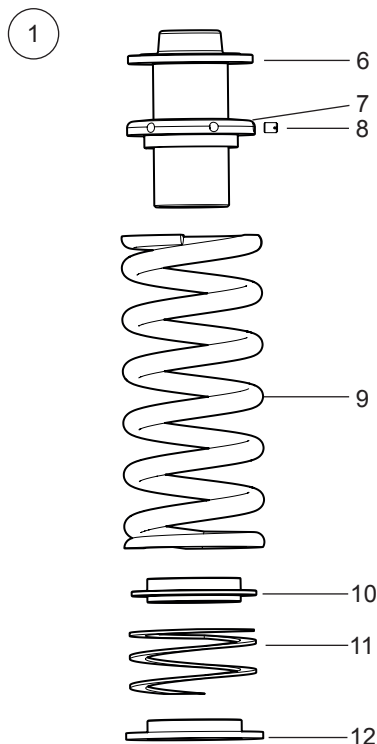

MOUNTING INSTRUCTIONS

9

Install the rear top mount to the rear shock absorber according to Fig 3:

Fit the top mount (5), the washer (3), the screw (2) and the lock nut (4) and tighten to 80 Nm.

10

Install the shock absorber to the vehicle starting with the top mount and the upper attachments. Use the included M8 screws (13).

11

Fasten the lower attachment and position the damper so that the adjusters are facing the rear of the vehicle according to Fig 4.

Note!

Make sure that all bolts are tightened to the correct torque and that nothing fouls or restricts movement of the strut when it is being fully compressed or extended. Some of the original bolts need to be replaced when removed. See the service manual for your vehicle or contact an Öhlins dealer.

12

Make sure that all removed parts are reinstalled in the same way as they were before the installation of the Öhlins shock absorber.

13

Reinstall the wheel.

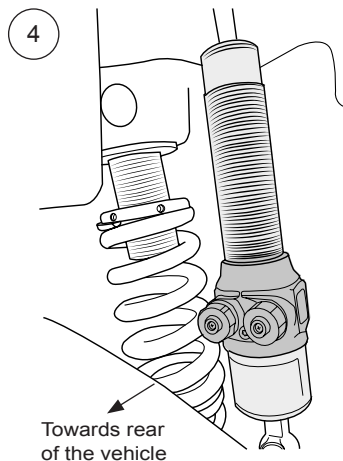
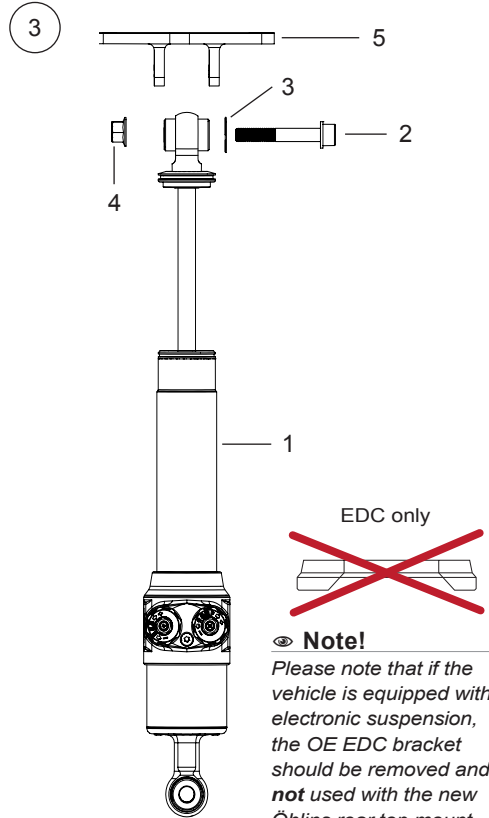

ADJUSTMENTS

⚠ Warning!

Before you ride/drive, always make sure that the setup is according to the recommended setup data. Read about adjustments and setting up in the Öhlins Owner's Manual before you make any adjustments. Contact an Öhlins dealer if you have any questions about setting up.

SETUP DATA

	Street	Track
Compression damping	12 clicks	10 clicks
Rebound damping	15 clicks	10 clicks

Recommended Springs

Main Spring

Model	Length	Rate	Öhlins#
M2	170 mm	200 N/mm	48170-37
M3/M4	170 mm	220 N/mm	48170-41

Helper spring

Length	Rate	Öhlins#
73 mm	7.5 N/mm	05173-12

Recommended spring adjuster position

For BMW M2 models: X= 46 mm

For BMW M3/M4 models: X= 43 mm

Adjust the installed spring package length by turning the spring preload adjuster until desired ride height is achieved.

Depending on car model and equipment, the ride height at the recommended installed spring package length may vary.

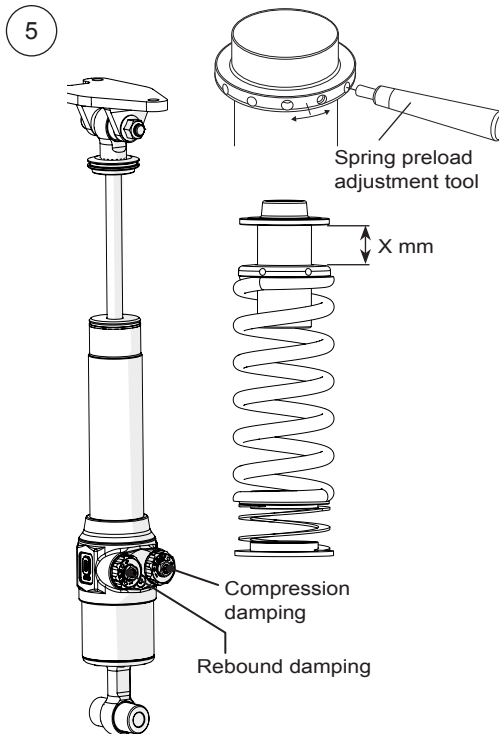

Öhlins products are subject to continuous improvement and development, therefore, although these instructions include the most up-to-date information available at the time of printing, minor updates may occur.

To find the latest information contact an Öhlins distributor. Please contact Öhlins if you have any questions regarding the contents in this document.

Part no. MI_BMW MU21_0
Issued 2023-10-09

© Öhlins Racing AB. All rights reserved. Any reprinting or unauthorized use without the written permission of Öhlins Racing AB is prohibited.

Öhlins Racing AB
Box 722
S-194 27 Upplands Väsby, Sweden
Phone +46 8 590 025 00
fax +46 8 590 025 80



www.ohlins.com