



Öhlins Shock absorber for Automotive  
**TPX/TTX44**

Owner's Manual





*Öhlins Headquarters Upplands Väsby, Sweden*

### **Öhlins Racing AB - The Story**

It was the 1970's, a young man named Kenth Öhlin spent most of his spare time pursuing his favourite sport: motocross.

Being a careful observer, Kenth's attention was continuously drawn to one specific detail - motocross bikes had more engine power than their suspension could handle. It was not long before Kenth realised that better performance could be achieved by improved wheel suspension.

Öhlins Racing was established in 1976, and just two years later the company won its first World Championship title. Despite being in the business for almost 40 years, the search for perfection and new functions is still the main focus of the company.

Congratulations! You are now the owner of an Öhlins product. More than two hundred World Championships and other major world titles are definitive proof that Öhlins products offer outstanding performance and reliability.

Every product has gone through rigorous testing and engineers have spent thousands of hours, doing their very best to use every possible experience from our almost 40 years within the racing sport.

The product that you now have in your possession is pure racing breed that is built to withstand.

By installing this product on your vehicle you have made a clear statement... you are a serious rider or driver with a focus on getting the maximal handling ability and outstanding feedback from your vehicle. Along comes the fact that your Öhlins product will be a long lasting friend, delivering the very best of comfort and performance every time you go for a ride. Go explore!

# SAFETY PRECAUTIONS

## General Warnings

### **Note!**

*The shock absorber/front fork/steering damper is an important part of the vehicle and will affect the stability.*

### **Note!**

*Read and ensure you understand the information in this manual and other technical documents provided by Öhlins, before using the product.*

### **Note!**

*Öhlins Racing AB can not be held responsible for any damage to the shock absorber/front fork/steering damper, vehicle, other property or injury to persons, if the instructions for mounting, usage and maintenance are not followed exactly.*

### **Warning!**

*After installing the Öhlins product, take a test ride at low speed to ensure your vehicle has maintained stability.*

### **Warning!**

*If the suspension makes an abnormal noise, or the function is irregular, or if you notice any leakage from the product, stop the vehicle immediately and return the product to an Öhlins dealer.*

### **Warning!**

*The product warranty shall only apply if the product has been operated and maintained in accordance with recommendations in this manual. If you have any questions regarding usage, service, inspection and/or maintenance please contact Öhlins.*

### **Warning!**

*This product was developed and designed exclusively for a specific vehicle model and shall only be installed on the intended vehicle model in its original condition as delivered from the vehicle manufacturer.*

### **Warning!**

*This product contains pressurized nitrogen gas (N<sub>2</sub>). Do not open, service or modify this product without proper education (Öhlins dealer) and proper tools.*

## SAFETY SYMBOLS

*In this manual, mounting instructions and other technical documents, important information concerning safety is distinguished by the following symbols:*



*The Safety Alert Symbol means: Warning! Your safety is involved.*

### **Warning!**

*The Warning Symbol means: Failure to follow warning instructions can result in severe or fatal injury to anyone working with, inspecting or using the shock absorber, or to bystanders.*

### **Caution!**

*The Caution Symbol means: Special precautions must be taken to avoid damage to the shock absorber.*

### **Note!**

*The Note Symbol indicates information that is important regarding procedures.*

### **Note!**

*When working with the Öhlins product, always read the vehicle service manual.*

### **Note!**

*This manual shall be considered as a part of the product and shall accompany the product throughout its life cycle.*

# CONTENTS

Adjustment and setting up.....	4
Spring preload .....	5
Spring set-up .....	6
Compression and rebound.....	6
How to adjust .....	7
Camber bushings.....	9
Inspection and maintenance .....	9

*Congratulations on choosing the Öhlins TPX/TTX44 high performance shock absorber - the most unique and powerful shock absorber available today. The TPX44 is a McPherson type whereas the TTX44 is a twin tube type shock absorber. Both are available with three way adjusters, high and low speed compression with rebound adjusters as well as with the new updated Progressive Damping System (PDS). The TPX/TTX44 shock absorber design is the culmination of three decades of Öhlins successful participation in World Championship events.*

This shock absorber draws on all the expertise developed by Öhlins while winning more than a hundred World Championships.

The TPX/TTX44 shock absorbers are designed to handle the demanding damping characteristics needed for all types of roads. For best performance, the shock absorber must be adjusted to different driving conditions; for the smooth and fast gravel roads in Finland or the rougher roads in Greece or in the Middle East. The Öhlins TPX/TTX44 features a patented concept with a unique design, that allows for

the gas pressure to always back-up the low-pressure side of the piston to keep pressure at a controlled level. Both concepts enable totally separated adjusters for compression and rebound damping.

Temperature stability is maintained by a flow restriction design in the bleed valves that creates a turbulent flow at very low piston velocities. Also, materials with different thermal expansion rates are used to compensate for the viscosity change of the fluid caused by changes in temperature.

In addition the Öhlins shim system offers infinite combinations of shim stacks, with a wide spectrum of different character using the same piston. The whole system is pressurized by nitrogen gas behind a floating piston to ensure separation of the gas and fluid.

The Öhlins TPX/TTX44 shock absorbers are racer friendly shock absorbers, easy to set up, dial in and rebuild. Remember that you can always get support from the Öhlins dealers worldwide.

# ADJUSTMENT AND SETTING UP

## Set up the vehicle

Installing new shock absorbers may change the ride height and wheel angles on your vehicle. Therefore, we recommend to do a complete set-up check of the vehicle after you have installed the Öhlins shock absorber.

1. Check ride height, front and rear. Note ride height. Adjust if necessary.
2. If scales are available, check corner weight, front and rear. Note measures. Adjust if necessary.

### **Note!**

---

*Always consult an Öhlins dealer if you have any questions regarding shock absorber/strut set-up.*

---

## Make adjustments

Suspension settings depend on the vehicle weight, the driving style and the road conditions. If you are not happy with our recommended settings, follow these few guidelines and ground rules on how to make adjustments.

### **Note!**

---

*Always start with the settings recommended by Öhlins.*

---

### **Note!**

---

*Higher click numbers give less damping force.*

---

- Make adjustments in small steps (2-3 at a time) and not outside the usable click range, take notes. See the Mounting instructions or contact an Öhlins dealer.
- When you think you have made an improvement, go back to the adjustment settings you started with, and double check to be sure.
- Pay attention to changes in conditions like tires or temperatures, etc. In general, compression damping changes should be used to influence the vehicle stability and response, while rebound damping changes should be used to influence comfort and traction.
- When you need more damping force, you should mainly try to increase compression damping and use as little rebound damping as possible. This usually means that you gain comfort and handling performance.

# SPRING PRELOAD

When adjusting the spring preload you move the spring seat which will lower or raise the vehicle ride height. The ride height is an important criteria for the vehicle stability and behaviour.

## 👁 Note!

For correct tools, contact an Öhlins dealer.

## 👁 Note!

For recommended spring preload, see Mounting instructions or contact an Öhlins dealer.

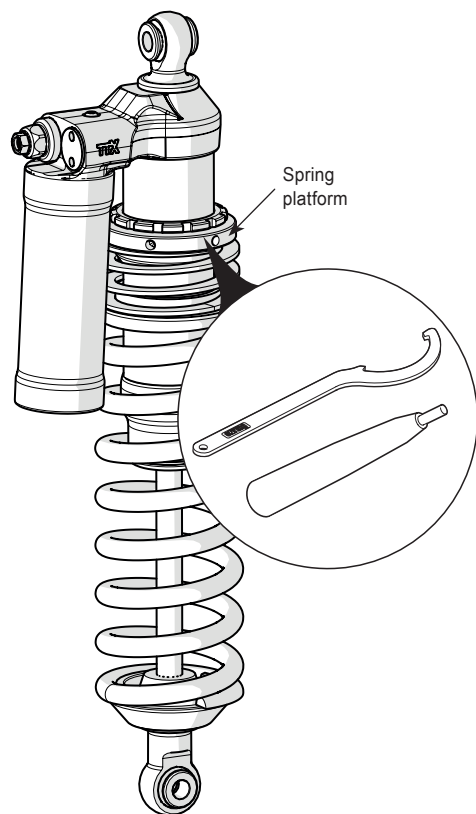

### Set the spring preload - type 1

1. Use the C-spanner to unlock the lock nut.
2. Turn the spring platform with the Preload adjuster tool to the desired position.
3. After adjusting, make sure to lock the lock nut.

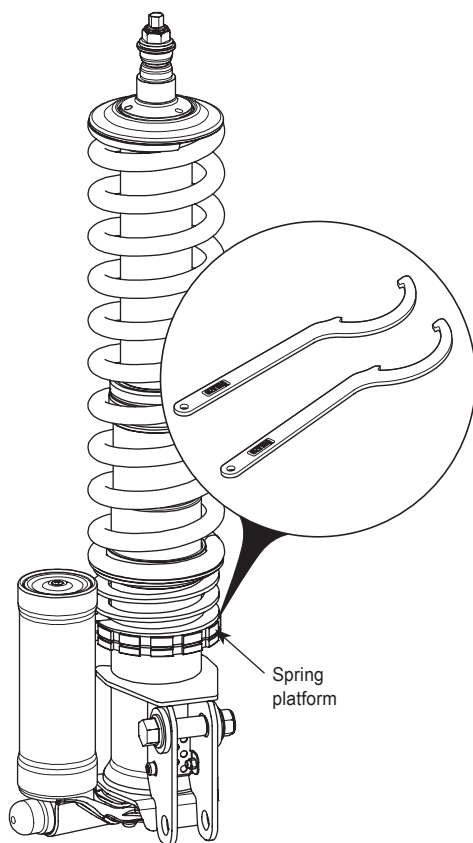

### Set the spring preload - type 2

1. Use two C-spanners to unlock the lock nut.
2. Turn the spring platform to the desired position.
3. After adjusting, make sure to lock the lock nut.



# SPRING SET-UP

There are a number of springs available for both gravel and tarmac to suit different driving conditions. For rougher gravel conditions we recommend to use one step stiffer springs but also increase ride height 10-20 mm depending on the conditions. It usually gives a better result than to use an even stiffer spring and less ride height change.

For very rough conditions like Middle East rallies even stiffer springs is recommended. For specific spring recommendations for your vehicle please see the Mounting Instructions or contact an Öhlins dealer.

## COMPRESSION AND REBOUND

### Compression and rebound damping

Compression damping controls the energy absorption when the shock absorber is compressed, thus controls how easy the shock absorber compresses when you hit a bump.

Rebound damping controls the energy absorption when the shock absorber is extended and controls how fast the shock absorber returns to its normal position after being compressed.

### Compression damping adjuster

Low speed compression is mainly used to control chassis movements and response but it also affects the traction. It affects how the car behaves during breaking, turn in and acceleration. Less low speed compression gives more chassis movement but in many cases it can improve traction and grip. Therefore it is possible to balance the car by adjusting the low speed compression.

High speed compression mainly affects how the car absorbs bumps and jumps. In rougher conditions or with a lot of jumps more high speed damping is often necessary to control the big chassis movements.

### Rebound damping adjuster

Rebound adjuster affects chassis movement in a similar way as the low speed compression but has even more influence on traction. Use this adjuster to control chassis movements over crests or after jumps. More rebound gives less movement and better stability but too much will cause a loss of traction. It is therefore a powerful balance tool together with the low speed compression adjuster.

For slippery conditions when grip levels are low, a softer set up on both rebound and low speed compression is a way to gain more traction.

### Recommended set up

For recommended set up, see the Mounting instructions or contact an Öhlins dealer. Driver preferences and driving conditions will affect how the shock absorbers should be set up but the recommended setup is a good starting point. For latest updates contact an Öhlins dealer.

# HOW TO ADJUST

## Rebound damping adjuster

### TTX44 Mkl Shock absorber

The TTX44 (Mkl) has two rebound adjusters. The adjuster in the shaft end eye, or at the end of the piston rod, is the main adjuster and the one in the cylinder head is for fine tuning.

#### **Caution!**

*Turn gently not to damage delicate sealing surfaces. Hand tighten only.*

### To adjust rebound damping

1. Use a 3 mm Allen key or Adjustment tool (01822-02).
2. Turn the adjuster clockwise to fully closed position (position zero [0]).
3. Turn counter clockwise to set the adjuster to recommended number of clicks (see recommended set up in the Mounting instructions or contact an Öhlins dealer).
4. If you want to change setting, adjust in steps of 2-3 clicks at a time. Focus on the main adjuster but if you are outside the recommended range use the fine adjuster.

### TTX44 Mkl

Useful adjustment range

Main	5-50 clicks
Fine	2-15 clicks

### TTX44MklII

Rebound 5-50 clicks

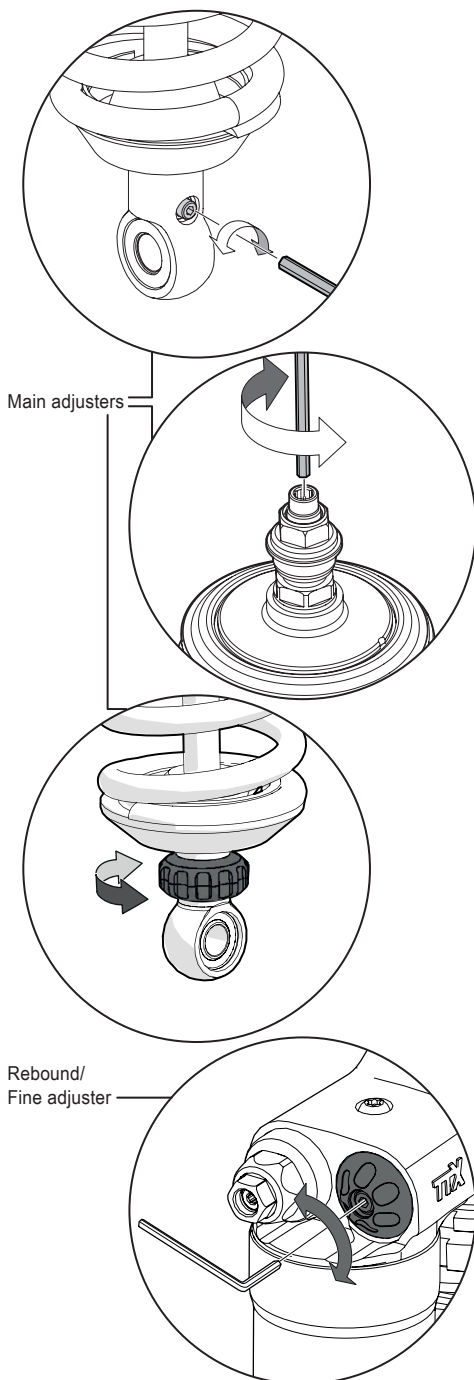



# HOW TO ADJUST

## To adjust

Turn the adjuster clockwise to fully closed position (position zero [0]). Then, turn counter clockwise to open, and count the clicks until you reach the recommended number of clicks. We recommend to adjust rebound in steps of 2-3 clicks at a time.

### ⚠ Caution!

*Turn gently not to damage delicate sealing surfaces. Hand tighten only.*

## Rebound damping adjuster

### TPX44

To adjust, use Rebound adjustment tool (01822-03), delivered with the damper (or contact an Öhlins dealer). Adjustment range is up to 60 clicks depending on the setting.

## Compression damping adjuster

### TPX and TTX44

#### One way compression

To adjust, use a 3 mm Allen key. Adjustment range 24 clicks.

### ⚠ Caution!

*Do not turn the 14 mm hexagon.*

#### Two way compression

##### Low speed compression

To adjust, use a 3 mm Allen key. Adjustment range 40 clicks

##### High speed compression

To adjust, use a 12 mm wrench. Adjust in steps of 3-5 clicks to fine tune the set up. Adjustment range: 50 clicks.

Rebound adjuster

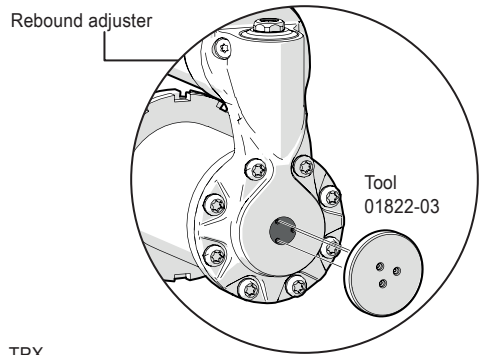

TPX one way compression adjuster

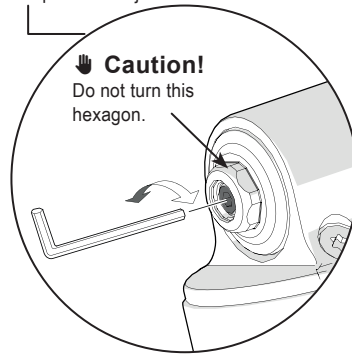

TPX and TTX MkI/MkII two way compression adjuster

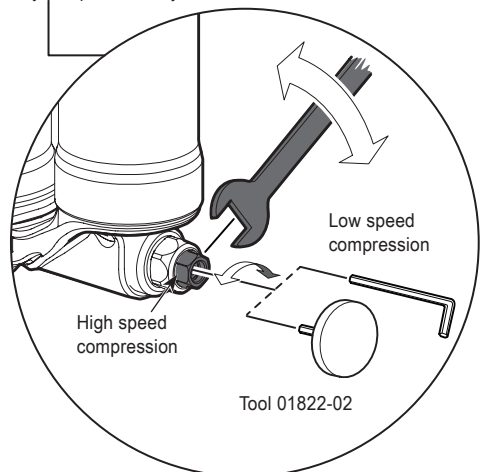

# CAMBER BUSHINGS

## Camber bushings

Unlike most standard McPherson struts, most Öhlins struts feature camber bushings that enable you to alter the wheel camber.

### Bushing type Identification marking

5194	grooves
5794	id number

You will obtain different camber angles depending on how you mount the bushings, with the eccentric hole facing the wheel or away from the wheel.

#### **Note!**

Contact an Öhlins dealer for recommendations regarding camber bushings.

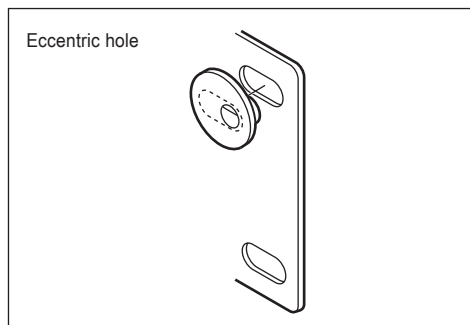
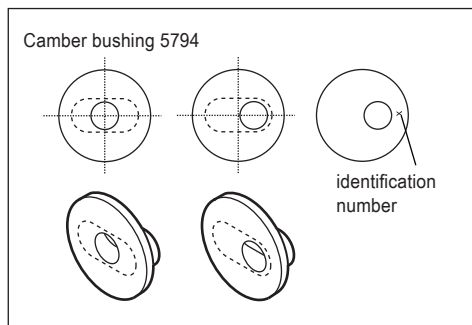
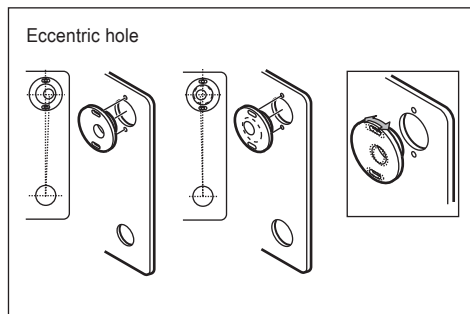
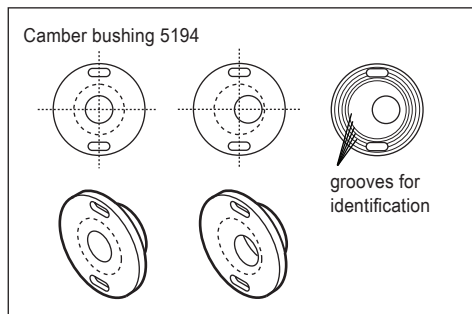

## INSPECTION AND MAINTENANCE

### Maintenance

#### TPX and TTX shock absorbers

Service your damper(s) according to the recommendations in the table:

#### **Warning!**

*Never alter the gas pressure. Special purpose charging equipment and access to nitrogen is required. The gas pressure should normally never be altered.*

Driving condition	Service after
<b>Smooth gravel</b>	
max working temp 90°	800km
<b>Medium gravel</b>	
max working temp <110°	700km
<b>Rough gravel</b>	
max working temp >110°	350km
<b>Tarmac</b>	1000km

# INSPECTION AND MAINTENANCE

Preventive maintenance and regular inspection reduces the risk of functional disturbance. If there is any need for additional service, please contact an Öhlins dealer.

## Cleaning

Clean the shock absorber externally with a soft detergent. Use compressed air. Be careful that all dirt is removed. Lift the bump rubber and clean the area below. Keep the shock absorber clean and spray it with oil (WD40, CRC 5-56 or equivalent) after washing. Wipe off excessive oil with a cloth.

## ⚠ Caution!

Never spray water directly into the adjuster knobs and/or the ball joints.

## TTX Inspection points

→ Every 300-400km

1. Check ball joints/ brackets for possible excessive play or stiction.

Removing the scraper holder (TPX only)

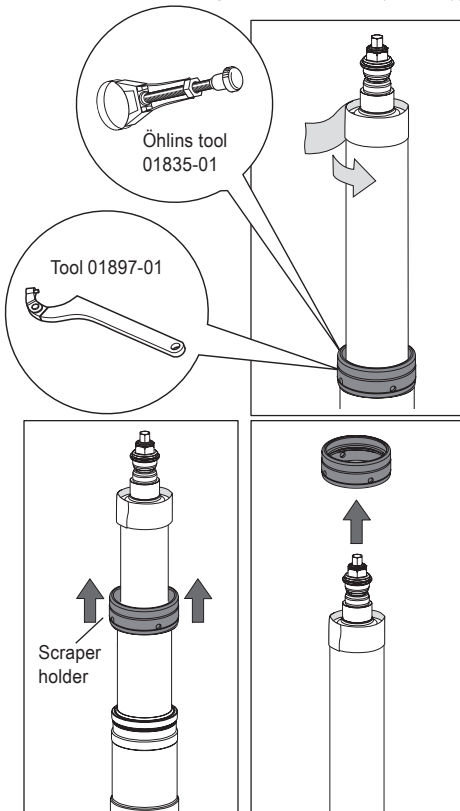

2. Check the piston shaft for damage that can cause leakage.
3. Check the shock absorber body for external damage.
4. Check the external reservoir for damage that can restrict the floating piston from moving freely.
5. Make sure that the reservoir is protected against stone chip.
6. Check the attachment of the shock absorber to the vehicle.

## TPX Inspection points

→ Every 300-400 km

1. Remove the scraper holder from the outer tube with Seal holder tool (01835-01) or C-spanner AMF (01897-01). Cover the clip groove at the top of the cylinder tube with tape and pull the scraper holder off the cylinder tube - see figure.
2. Remove the cartridge from the front outer tube by removing the bottom screws.
3. Clean all parts with a soft detergent.
4. Check scraper and bushings for wear and/or damages and change if necessary.
5. Apply a layer of Öhlins grease on the cylinder tube, scraper and bushings. The space between the bushings in the outer tube should be filled with a layer of grease up to the bushing surface.

### Low temperature applications:

Use the Öhlins grease (10231-81)

### Medium temperature applications:

Use the Öhlins red grease (00146-xx) or the Öhlins grease (10231-81)

### High temperature applications:

Use the Öhlins red grease (00146-xx)

Recommended highest/lowest working temperature::

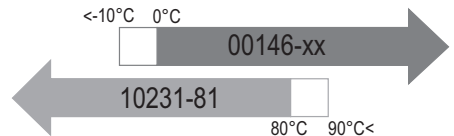

6. Assemble the strut and tighten all bottom screws (10 Nm), use copper paste on the threads.
7. Install the scraper holder with tool Seal holder tool (01835-01) or C-spanner AMF (01897-01) on the outer tube and hand tighten to 20 Nm.

Your Öhlins retailer:

Öhlins Racing AB  
Box 722  
SE-194 27, Upplands Väsby  
Sweden

Phone: +46 (0)8 590 025 00  
Fax: +46 (0)8 590 025 80  
[www.ohlins.com](http://www.ohlins.com)



[www.ohlins.com](http://www.ohlins.com)