

👁 Note!

Please note that there can be small differences between your product and the images in these instructions.

👁 Note!

Please note that during storage and transport, especially at high ambient temperature, some of the oil and grease used for assembly may leak and stain the packaging. This will not cause damage to the product, wipe off the excessive oil or grease with a cloth.

Kit Contents		
Description	Part No	Pcs
Sticker	00192-01	2
C-spanner	01796-01	1
Rebound adj. Tool	01822-03	1
Foam filter	06057-07	2
Owners manual	07440-02	1
Camber bushings:		
no. 0 offset 3.0	05794-00	2
no. 1 offset 2.44	05794-01	2
no. 2 offset 1.88	05794-02	2
no. 3 offset 1.32	05794-03	2
no. 4 offset 0.76	05794-04	2

👁 Note!

Before you install this product, check the kit contents. If anything is missing, please contact an Öhlins dealer.

⚠ Warning!

Before you install this product, read the Öhlins Owner's manual. This product is an important part of the vehicle and the vehicle stability.

McPherson Strut for Subaru Impreza Grp N Tarmac - Front

SUR 5P04

Mounting Instructions



MOUNTING INSTRUCTIONS

⚠ Warning!

We strongly recommend to let an Öhlins dealer install this product.

⚠ Warning!

If you work with a lifted vehicle, make sure that it is safely supported to prevent it from tipping over.

👁 Note!

When you work with this product, see the vehicle service manual for vehicle specific procedures and important data.

👁 Note!

Before you install this product clean the vehicle.

1

Raise the vehicle so that the front wheels are off the ground.

2

Remove the front wheels.

3

Loosen the lower attachment bolts.

👁 Caution!

Support the wheel hubs on each side of the vehicle not to damage the brake hose and/or drive shaft joint.

4

Loosen the upper attachment from the top mount. Remove the original McPherson shock absorbers.

5

Install the Öhlins McPherson shock absorbers in the original top mount.

Install the spacer 05952-07 (17 mm) below the top mount.

Install the spacer 05952-05 (12 mm) above the top mount.

Tighten the top nut (00139-04) to 60 Nm.

6

Lift the wheel hub with a hydraulic jack. Use appropriate camber bushings and sleeve (00123-19) to reduce free play before tightening the bolts to the wheel upright.

👁 Note!

Lower the vehicle so that the suspension is slightly compressed before tightening the screws.

👁 Caution!

Do not use an impact wrench when removing the shock absorber from the top mount. An impact wrench may cause the piston nut to come loose from the piston shaft.

👁 Caution!

Ensure that all screws are tightened to the correct torque and that nothing fouls or restricts movement of the shock absorber/front fork/steering damper when the suspension is fully compressed or extended.

MOUNTING INSTRUCTIONS

Reservoir bracket position

Left front

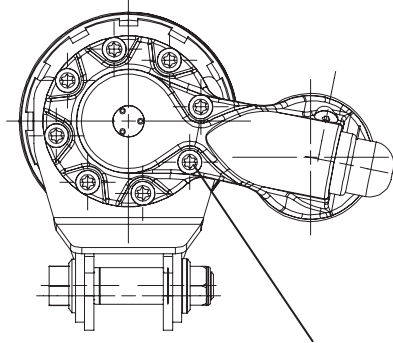

Tightening torque 10 Nm (8x).
Apply copper paste on the threads.

Reservoir bracket position

Right front

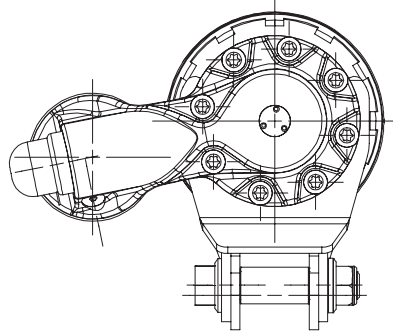

ADJUSTMENTS

⚠ Warning!

Before you ride/drive, always make sure that the setup is according to the recommended setup data. Read about adjustments and setting up in the Öhlins Owner's Manual before you make any adjustments. Contact an Öhlins dealer if you have any questions about setting up.

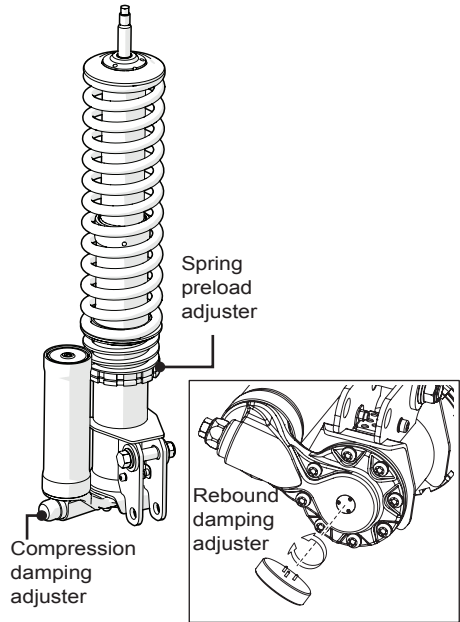

SETUP DATA

Shock absorber length	518	mm
Stroke	180	mm
Spring preload	28	mm
Compression damping		
Low speed (3 mm Allen)	18	clicks
High speed (12 mm Allen)	15	clicks
Rebound	26	clicks

	Part no	N/mm
Installed spring	06774-19	70
Optional spring	06774-15	60
	06774-17	65
	06774-21	75

Öhlins products are subject to continuous improvement and development, therefore, although these instructions include the most up-to-date information available at the time of printing, minor updates may occur.

To find the latest information contact an Öhlins distributor. Please contact Öhlins if you have any questions regarding the contents in this document.

Part no. MI_SUR5P04_0
Issued 2014-06-23

© Öhlins Racing AB. All rights reserved. Any reprinting or unauthorized use without the written permission of Öhlins Racing AB is prohibited.

Öhlins Racing AB
Box 722
S-194 27 Upplands Väsby, Sweden
Phone +46 8 590 025 00
fax +46 8 590 025 80



www.ohlins.com