

Adjustments

⚠ Warning!

Before driving, always make sure that the basic settings made by Öhlins are according to recommended Set-up Data. Read about adjustments and setting up in the Öhlins Owner's Manual before you make any adjustments. Contact an Öhlins dealer if you have any questions about setting up the shock absorber.

The standard preload is 2 mm from a free length of 200 mm, giving 198 mm installed length, see fig ③.

Set-up Data

Recommended set-up

Rebound 10 clicks
Spring preload 2 mm
Shock absorber length 419 mm

Spring

Spec H200, ID65, 90N/mm

The actual vehicle height

With both the preload and height adjustments in their standard positions, the vehicle is lowered approximately 30 mm when compared to the original suspension. As the height adjuster is turned one rotation, the position moves 1.5 mm.

⚠ Warning!

The adjustment range is the standard position ± 15 mm. If the bracket is moved outside the adjustment range, it may come loose.

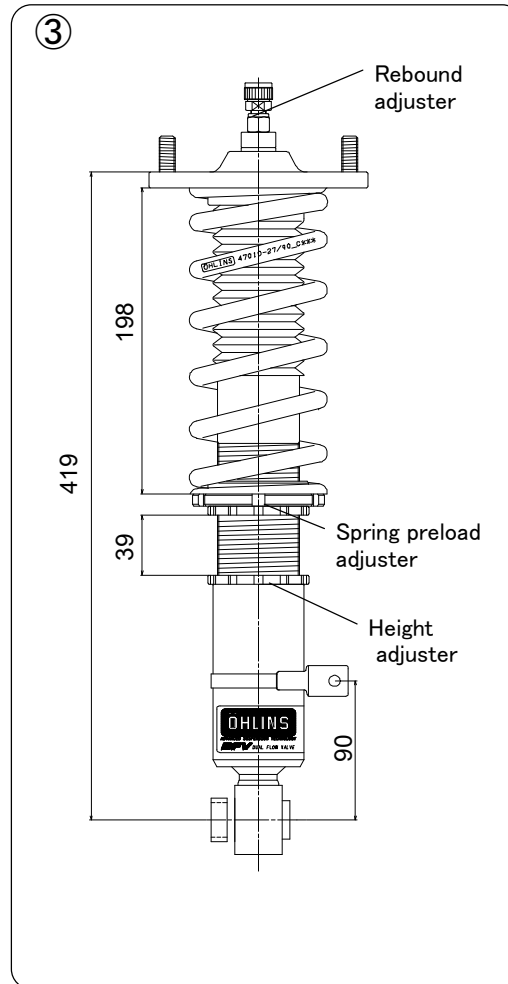

Before installing this product, check the contents of the kit. If anything is missing, please contact an Öhlins dealer.

Kit Contents	Pcs.
Shock absorber	2
Dust boot	2
Top mount	2
Spring	2
Nylon nut M10	2
Spacer t=10	2
Spacer t=7	2

MOUNTED ON SHOCK ABSORBER
Adjuster 2

USED FOR BOTH FRONT AND REAR

C-spanner	1
C-spanner	1
Öhlins sticker	1
Öhlins Owner's Manual	1

Please note that during storage and transportation, especially at high ambient temperature, some of the oil and grease used for assembling may leak and stain the packaging. This is in no way detrimental to the product, wipe off the excess oil/grease with a cloth.

⚠ Warning!

Before installing this product, read the Öhlins Owner's Manual. The shock absorber is an important part of your vehicle and will affect the stability.

Öhlins products are subject to continuous improvement and development, therefore, although these instructions include the most up-to-date information available at the time of printing, minor updates may occur.

To find the latest information contact your Öhlins distributor. Please consult your Öhlins dealer if you have any questions regarding the contents in this document.

Part no. NISM10.0
Issued 2010-01-30



Shock Absorber Kit for Nissan skyline GT-R (BNR34)

NIS MI10 front Mounting Instructions

© Öhlins Racing AB. All rights reserved. Any reprinting or unauthorized use without the written permission of Öhlins Racing AB is prohibited.

Öhlins Racing AB



www.ohlins.com



How to install

⚠ Warning!

It is advisable to have an Öhlins dealer install the shock absorber.
When installing, read your Vehicle Service Manual.



1

Raise the vehicle and put it on jack stands.

⚠ Warning!

Ensure that it is securely supported.

2

Remove the front wheels.

3

Remove the lower and the upper attachments and remove the original shock absorbers.

4

Cut the dust boot 52 mm from the lower end with a pair of scissors according to fig ②.

5

Tighten the lower spring seat and the lock nut to 50 - 60 Nm.
Fit the the dust boot, the spring, the top mount and the adjuster according to fig ①. Tighten the nylon nut to 20 Nm.

👁 Note!

When tightening the top mount nut, the shock absorber shaft must be held in position with a 4 mm Allen key.

6

Install the Öhlins shock absorbers on the vehicle.

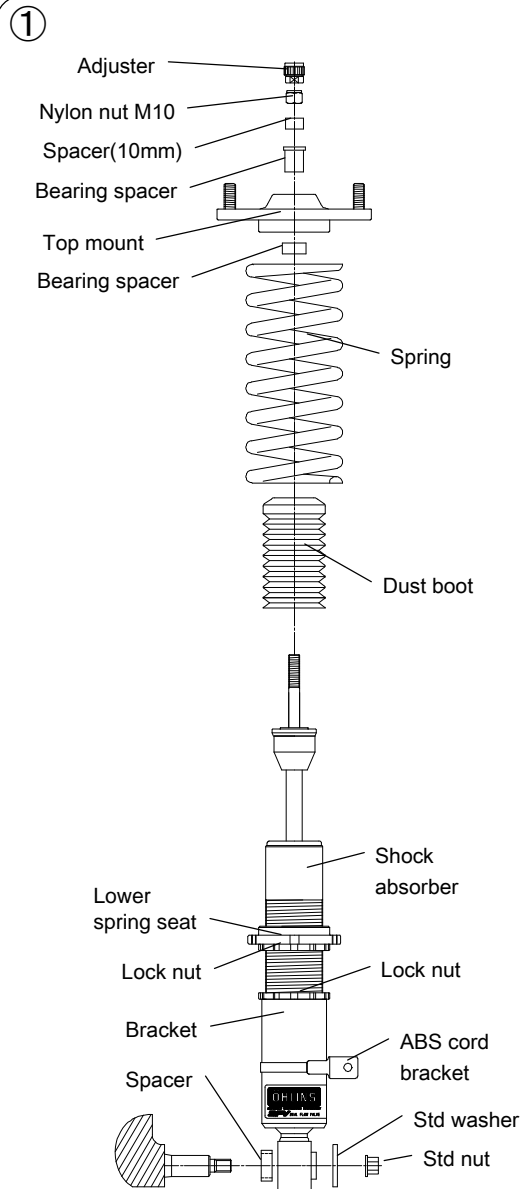

7

Fasten the upper attachments.

👁 Note!

Make sure that all bolts are tightened to the correct torque and that nothing fouls or restricts movement of the shock absorber when it is being fully compressed or extended.

8

Make sure that all removed parts are reinstalled in the same way as they were before the installation of the Öhlins shock absorber.

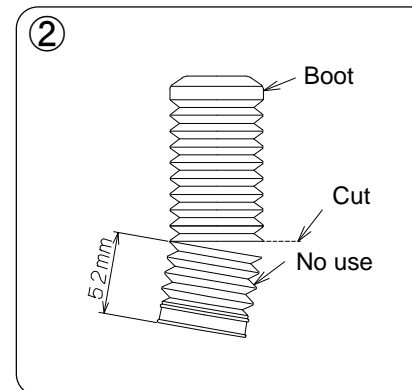

Adjustments

⚠ Warning!

Before driving, always make sure that the basic settings made by Öhlins are according to recommended Set-up Data. Read about adjustments and setting up in the Öhlins Owner's Manual before you make any adjustments. Contact an Öhlins dealer if you have any questions about setting up the shock absorber.

The standard preload is 2 mm from a free length of 180 mm, giving 178 mm installed length, see fig ④.

Set-up Data

Recommended set-up

Rebound 10 clicks
Spring preload 2 mm
Shock absorber length 670 mm

Spring

Spec H250, ID65, 80 N/mm

The actual vehicle height

With both the preload and height adjustments in their standard positions, the vehicle is lowered approximately 30 mm when compared to the original suspension. As the height adjuster is turned one rotation, the position moves 1.5 mm.

⚠ Warning!

The adjustment range is the standard position ± 15 mm. If the bracket is moved outside the adjustment range, it may come loose.

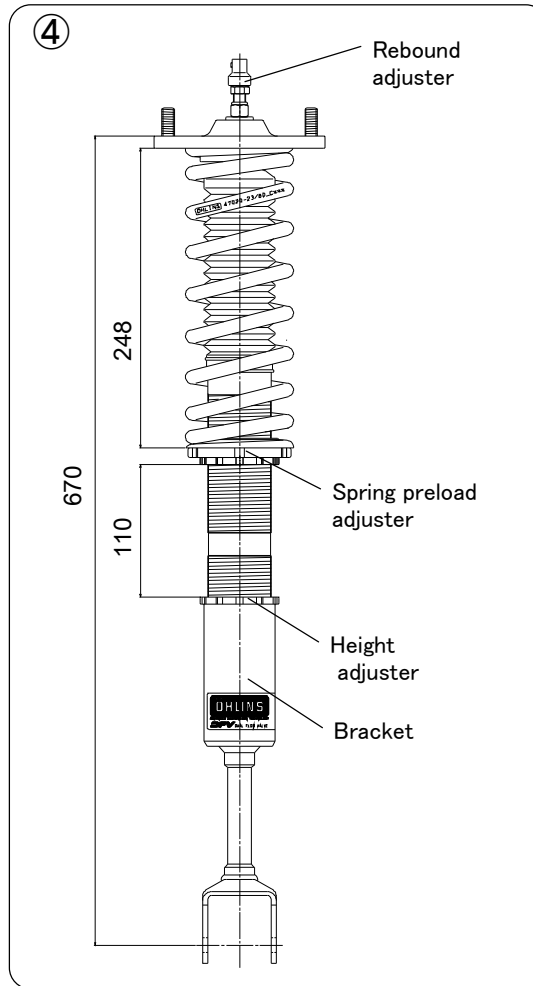

Before installing this product, check the contents of the kit. If anything is missing, please contact an Öhlins dealer.

Kit Contents	Pcs.
Shock absorber	2
Dust boot	2
Top mount	2
Spring	2
Screw M4	2
Control wire	2
Handle	2
Nylon nut M10	2
Allen key	1
Spacer t=5	2

MOUNTED ON SHOCK ABSORBER
Adjuster 2

USED FOR BOTH FRONT AND REAR
C-spanner 1
C-spanner 1
Öhlins sticker 1
Öhlins Owner's Manual 1

Please note that during storage and transportation, especially at high ambient temperature, some of the oil and grease used for assembling may leak and stain the packaging. This is in no way detrimental to the product, wipe off the excess oil/grease with a cloth.

⚠ Warning!

Before installing this product, read the Öhlins Owner's Manual. The shock absorber is an important part of your vehicle and will affect the stability.

© Öhlins products are subject to continuous improvement and development, therefore, although these instructions include the most up-to-date information available at the time of printing, minor updates may occur.

To find the latest information contact your Öhlins distributor. Please consult your Öhlins dealer if you have any questions regarding the contents in this document.

Part no. NISMI10_0
Issued 2010-01-30



Shock Absorber Kit for Nissan skyline GT-R (BNR34)

NIS MI10 rear

Mounting Instructions

© Öhlins Racing AB. All rights reserved. Any reprinting or unauthorized use without the written permission of Öhlins Racing AB is prohibited.

Öhlins Racing AB



www.ohlins.com



How to install

⚠ Warning!

It is advisable to have an Öhlins dealer install the shock absorber.
When installing, read your Vehicle Service Manual.



1
Raise the vehicle and put it on jack stands.

⚠ Warning!

Ensure that it is securely supported.

2
Remove the rear wheels.

3
Remove the lower and the upper attachments and remove the original shock absorbers.

4
Tighten the lower spring seat and the lock nut to 50 - 60 Nm.
Fit the dust boot, the spring, the top mount and the adjuster according to fig ①. Tighten the nylon nut to 20 Nm.

👁 Note!

When tightening the top mount nut, the shock absorber shaft must be held in position with a 4 mm Allen key.

5
Install the Öhlins shock absorbers on the vehicle.

6
Fasten the upper attachments.

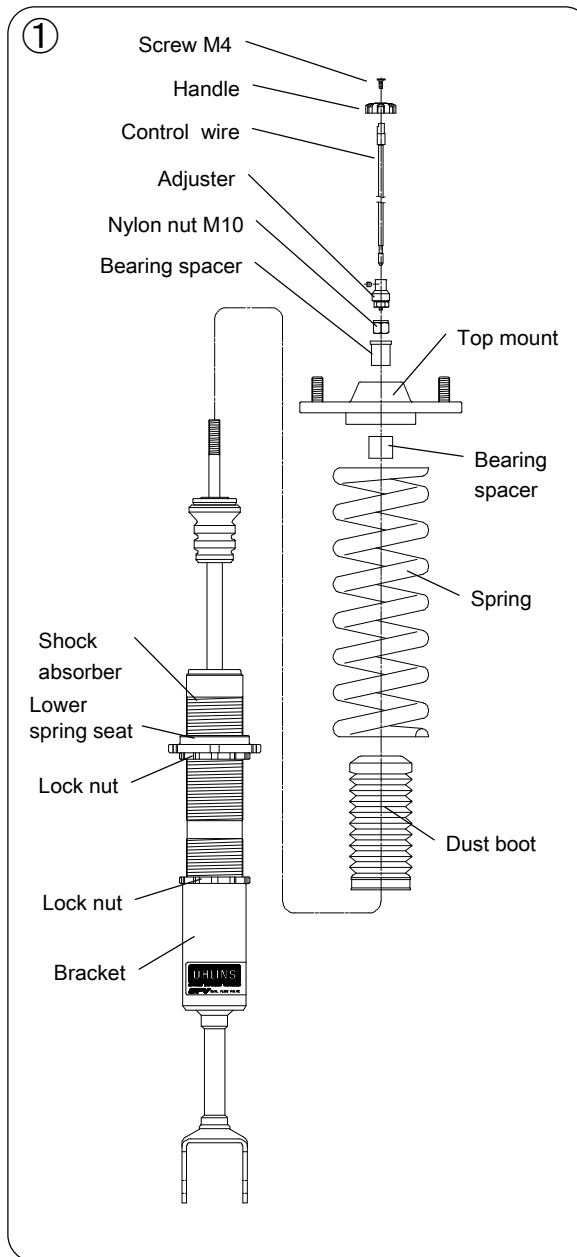

👁 Note!

Make sure that all bolts are tightened to the correct torque and that nothing fouls or restricts movement of the shock absorber when it is being fully compressed or extended.

7
Make sure that all removed parts are reinstalled in the same way as they were before the installation of the Öhlins shock absorber.

8
Sub-assemble the wire. (Fasten the handle by tightening the M4 screw.)
As shown in the fig ③, insert the wire through the oval hole in the speaker board and run it inside the vehicle. Insert the top end of the wire into the adjuster and fasten it with the supplied Allen wrench.

How to install

② In the case of installing to BCNR33, Move the controller.

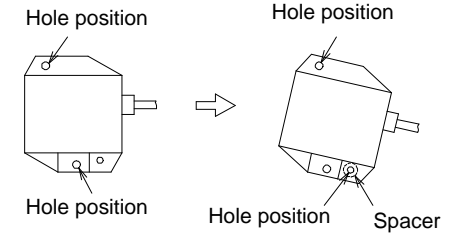

Right side of vehicle body under speaker board

