

Kit Contents		
Description	Part No	Pcs
Sticker ÖHLINS wh/tr	01185-01	2
Sticker ÖHLINS bl/tr	01185-04	2
Lock nut M12x1.25/7	00539-01	1
Circlip SRA 50 stainless	01499-07	1
Lock nut M18x1.5	05359-02	1
Support ring 12.1/50/24	05915-01	1
Spring seat retainer	05915-02	1
Sleeve 12.1/16/39	05916-03	1
Washer 12.1/37/4	05921-01	1
Ball joint spacer	06703-02	1
Ball joint spacer	06703-03	1
Spring seat 69.5/94/22	06765-03	1
Helper spring	05173-06	1
Spring guide	05193-09	1
Spring	06774-19	1
Only MIR3P54		
C-spanner	00710-02	1
C-spanner	01796-01	1
Owners manual	07440-02	1

Note!

Please note that there can be small differences between your product and the images in these instructions.

Note!

Please note that during storage and transport, especially at high ambient temperature, some of the oil and grease used for assembly may leak and stain the packaging. This will not cause damage to the product, wipe off the excessive oil or grease with a cloth.

Note!

Before you install this product, check the kit contents. If anything is missing, please contact an Öhlins dealer.

Warning!

Before you install this product, read the Öhlins Owner's manual. This product is an important part of the vehicle and the vehicle stability.

Shock absorber for Mitsubishi Lancer Evo X

MIR 3P54/4P54

Mounting Instructions



MOUNTING INSTRUCTIONS

⚠ Warning!

We strongly recommend to let an Öhlins dealer install this product.

⚠ Warning!

If you work with a lifted vehicle, make sure that it is safely supported to prevent it from tipping over.

👁 Note!

When you work with this product, see the vehicle service manual for vehicle specific procedures and important data.

👁 Note!

Before you install this product clean the vehicle.

1

Raise the vehicle so that the rear wheels are off the ground.

2

Remove the rear wheels.

3

Remove the original shock absorbers.

👁 Note!

To facilitate removal, compress the shock absorber.

🚫 Caution!

Do not use an impact wrench when removing the top mount from the shock absorber. An impact wrench may cause the piston nut to come loose from the piston shaft.

4

At delivery, the spring platform height is set for a shock absorber with rubber top mount. The spring platform height must be adjusted depending on which top mount you use.

4A Rubber Top Mount

Remove the top mount and the rubber mountings from the original shock absorber. Install the top mount and the bushings to the Öhlins shock absorbers.

4B RalliArt Top Mount

Assemble according to the figure.

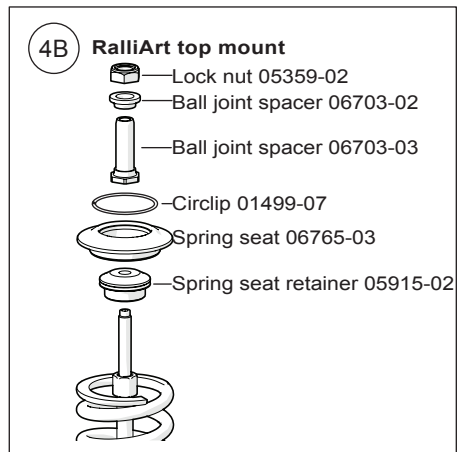
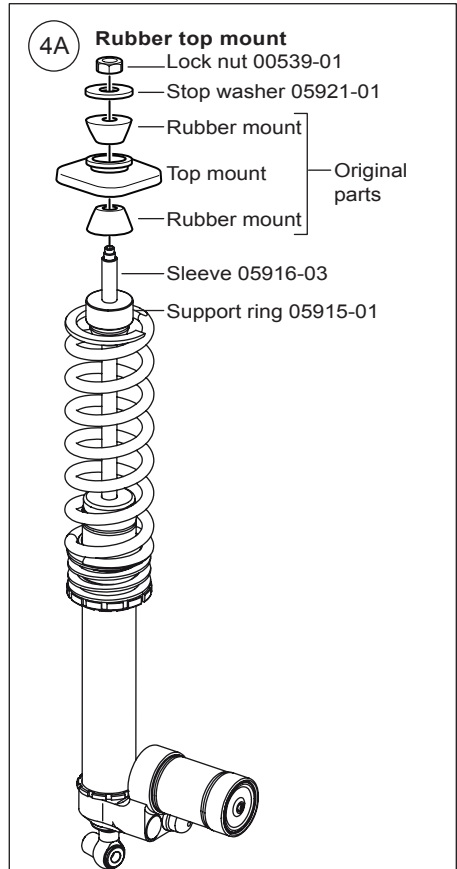

MOUNTING INSTRUCTIONS

5

Release the spring preload before installing the Öhlins shock absorbers to the vehicle.

6

Install the Öhlins shock absorbers. The reservoir pointing towards the rear and away from the wheel.

Note!

Lower the vehicle so that the suspension is slightly compressed before tightening the screws.

7

Set the spring preload when the shock absorbers are installed on the vehicle.

Caution!

Protect the reservoir from stones that can damage it. A damaged reservoir may cause poor function.

Caution!

Ensure that all screws are tightened to the correct torque and that nothing fouls or restricts movement of the shock absorber/front fork/steering damper when the suspension is fully compressed or extended.

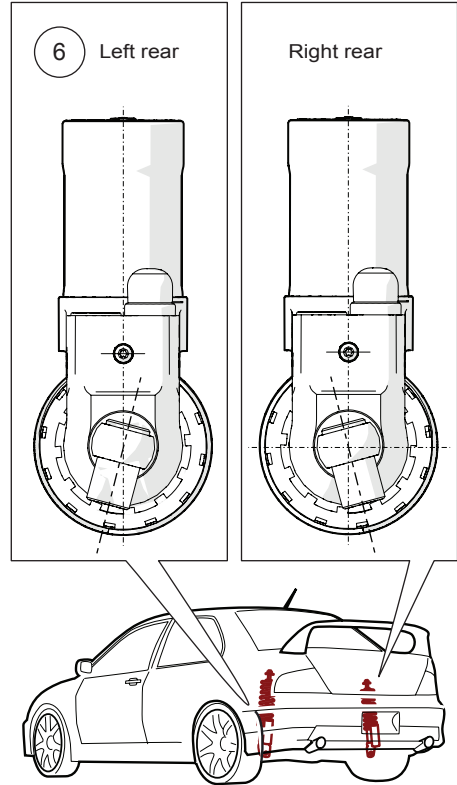

ADJUSTMENTS

⚠ Warning!

Before you ride/drive, always make sure that the setup is according to the recommended setup data. Read about adjustments and setting up in the Öhlins Owner's Manual before you make any adjustments. Contact an Öhlins dealer if you have any questions about setting up.

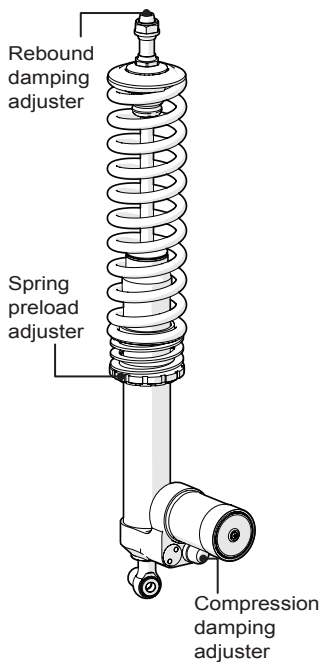

SETUP DATA

Length	610	mm
Stroke	160	mm
Spring part no.	06774-19	
Spring rate	70	N/mm
Comp high speed	30	
Comp low speed	12	
Rebound	20	

Optional springs	
Part No	Spring rate N/mm
06774-17	65
06774-21	75
06774-23	80

Öhlins products are subject to continuous improvement and development, therefore, although these instructions include the most up-to-date information available at the time of printing, minor updates may occur.

To find the latest information contact an Öhlins distributor. Please contact Öhlins if you have any questions regarding the contents in this document.

Part no. MI_MIR3P54_4P54_0
Issued 2014-08-04

© Öhlins Racing AB. All rights reserved. Any reprinting or unauthorized use without the written permission of Öhlins Racing AB is prohibited.

Öhlins Racing AB
Box 722
S-194 27 Upplands Väsby, Sweden
Phone +46 8 590 025 00
fax +46 8 590 025 80



www.ohlins.com